

Single Disc

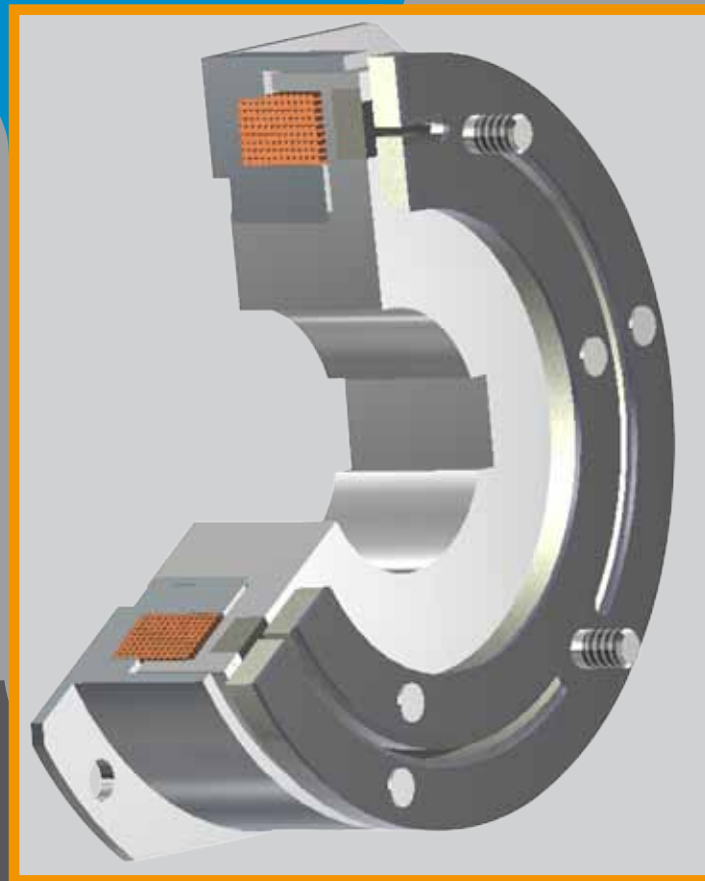

2&g

Elektro magnetische single disc
bremsen und klütschen

Electromagnetic single disc brakes and clutches (slip ring less)

Single disc clutches and brakes are not only used in common machine tool and heavy machinery but also in paper, printing, mixer, roller mill, elevator, as well as electro motor and diesel engines where they build an effective and economic solution.

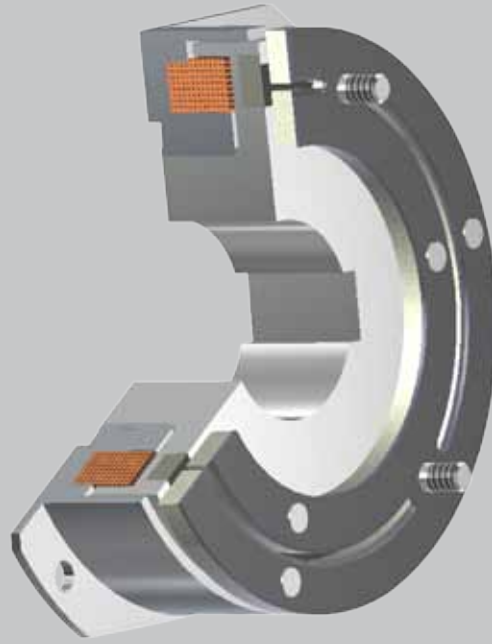

2

Clutches

The slipringless, electromagnetic single disc clutch contains out of following three components:

- Magnet body with coil (stationary)
- Rotor (mobil)
- Armature disc (mobile)

Structure: The magnet body is fixed on a housing. The rotor is bolt on to one of the shafts that need to be coupled (either the driving or the driven one) with a minimum radial distance to the magnet body. The armature disc will be fixed on the face of the counter shaft. Thus the respective design execution can be featured very flexible: Rotor or armature disc can be mounted on the driven as well as on the driving shaft and receive then a driving or driven function- according to the customized design.

It is important that all 3 components are inline centred: the permissible tolerances you will find in the relevant design specifications ("air gap tolerance").

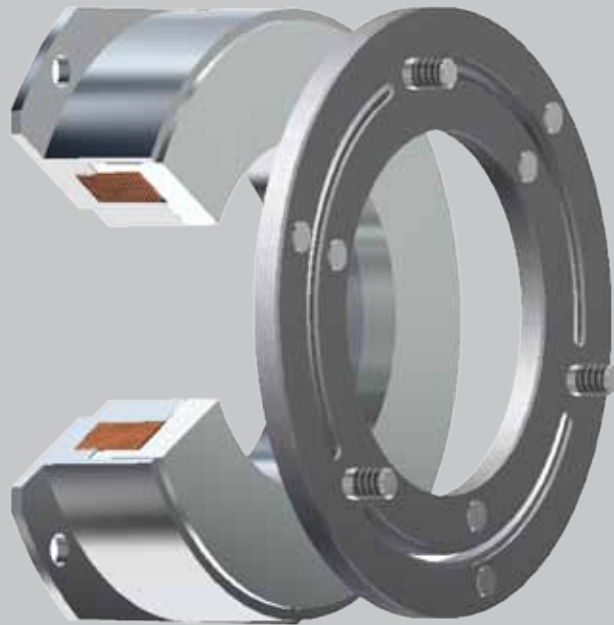

Brakes

The slipringless, electromagnetic single disc brakes contains out of the following three components:

- Magnet body with coil (stationary)
- Brake disc (integrated into the magnet body)
- Armature disc (mobile)

Structure: the brake disc is fixed to the magnet body and is therefore the counterpace to the armature disc, which is either on the driving or driven shaft, always according to customer specific application.

Due to electric DC Voltage to the coil a electromagnet filed presses the armature disc towards the metallic friction lining of the magnet body, causing that the one shaft is braked. The brake torque is carried via the fixed part, which is attached to the magnet body.

Structure and function

All electromagnetic single disc clutches and brakes from a&g use the powerful dynamic double composed electromagnetic field - means: a dual magnetic activation of the armature disc.

By feeding DC the force of the electromagnetic shifting membrane is activated and a backlash free transmission of the torque onto the output shaft is achieved. By cutting off the DC the clutch opens, so that the shifting membrane self displays from the magnet body and a safe, torque free separation is secured.

A short run-in time with multiple shifting's under differential speed is required for the brakes and clutches to achieve nominal torque during later operation.

In dry operation the units are insensitive against minor contamination by oil or grease.

A membrane spring transmit's the torque radial and completely backlash free. This spring will be fixed by screws on a counter piece (on the front face): this can be a flange or a driving or driven wheel.

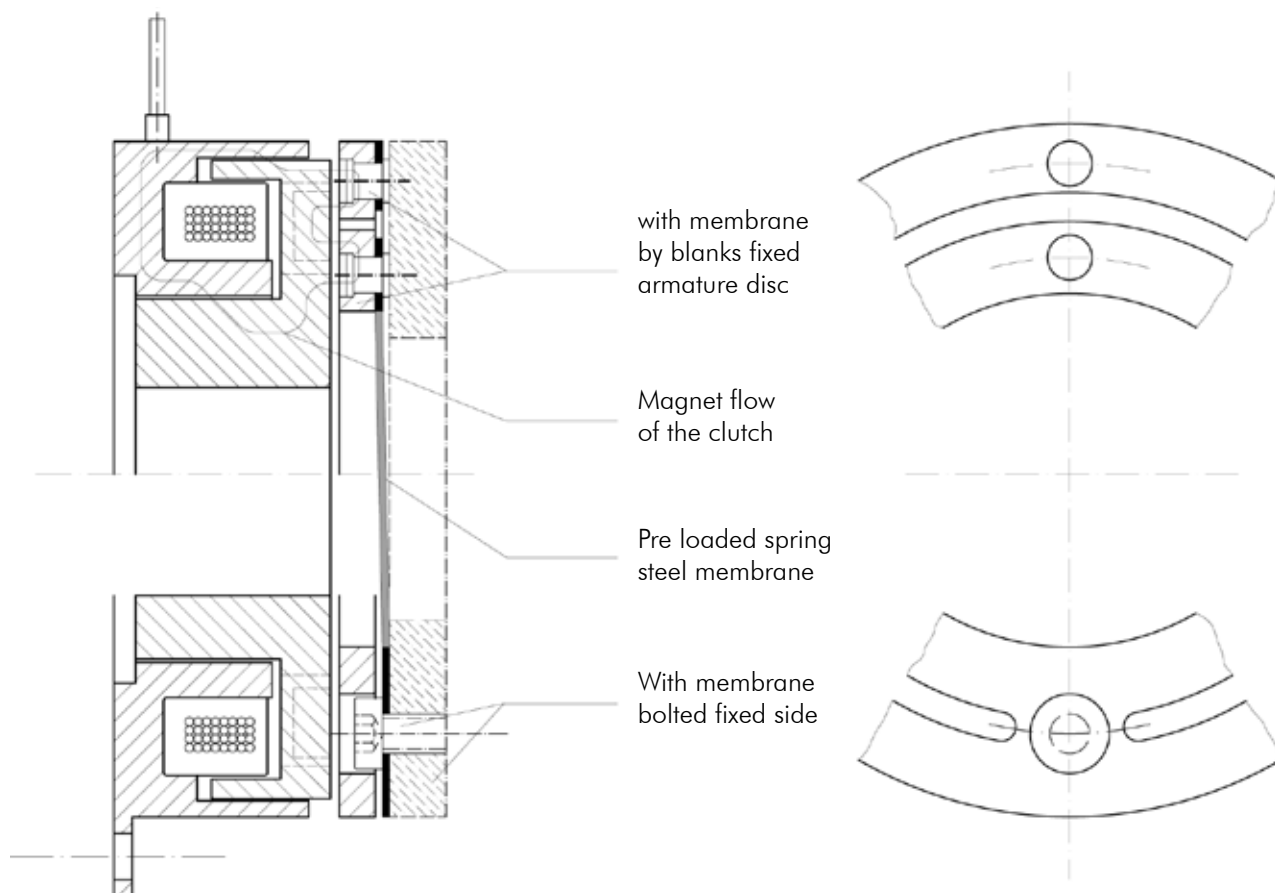

Advantages

- clutches and brakes are slipringless
- Maintenance free operation
- Suitable for dry and wet operation
- In dry operation insensitive against minor contamination (oil, grease etc.)
- Double magneto motive force of the armature disc allow compact build with bigger hollow diameter of the hub at high torques
- variants for high performance shifting with adjustable pole gap
- when switched off, complete separation without no load running torque
- Additional accessories available like: protective resistor, multiplier, and circuit switches for short switch times.

Technical features

Our clutches AK-AR and brakes AB-AR are torque optimized single disc variants with metallic friction surface and thus for mainly dry run operation.

In comparison to normal single disc versions we use double magnetic discharge of the pole surface, means the friction surface at the rotor (brake disc) and the friction surface of the split armature disc at the clutch or brake. When the coil is switched off, a complete separation between driving and driven side is achieved. Thus our versions are free of no load running torque and suitable for high rpm.

The frictional heat during shifting is derivated into the rotor (brake disc) and the armature disc, which allows a high shifting power per shifting. Another advantage is the precise shifting by spring steel membrane which offers good technical solutions for different applications.

Technical features

Operating condition

The pole surface of the friction clutch and brakes can also be used during wet operation. The transmittable torques are then reduced to 25-30 % of the value in dry run. With sufficient oil lubrication the operation is nearly free from wear and no maintenance is needed.

Thanks to the high friction resistance and self adjustment of the friction surface a regular maintenance of the unit is not required under dry run, only case to case check is sufficient.

During dry run contamination of the friction surface by oil or grease can cause a reduction of the transmittable torque. After some shifting's under load the origin values will be reached again.

Under new condition a short run in of the pole surface is required to achieve the specified data.

Electrical connection

All pole surface versions are operated by 24 V DC. Power fluctuation should not exceed +/- 5 %. The magnet coils are designed for 100 % duty cycle.

For protection against Induction during power off we recommend a parallel installed resistor with the value of 8 to 10 times the resistance of the coil of the unit.

Shifting times

The shifting times in the catalogue are approximate values. The shifting times are mainly influenced by the kind of assembly and the adjustment of the shifting distance (air gap "s").

A shortening of the closing time can be achieved via electrical shifting measures.

A shortening of the brake time "t2" can be achieved by higher pre tensioning of the shifting membrane.

DIN VDE 0580:2011-11

I Coil current

M₁ Transmittable torque

M₂ Shifting torque

M₃ No load running torque

M₄ Load torque

t₁ Closing time

t₂ Brake time

t₃ Acceleration time

t₁₁ On delay

t₁₂ Ramp response

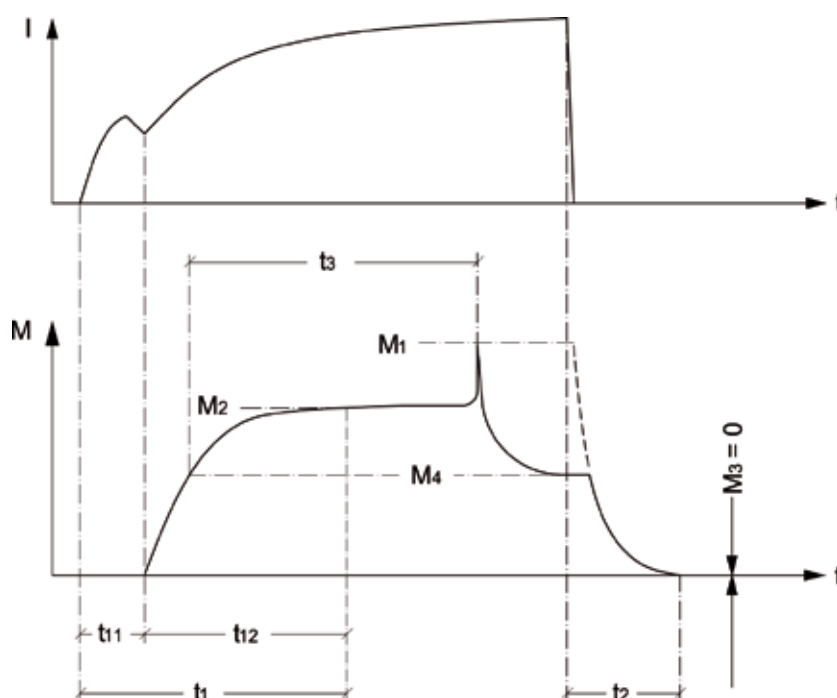

Installation examples

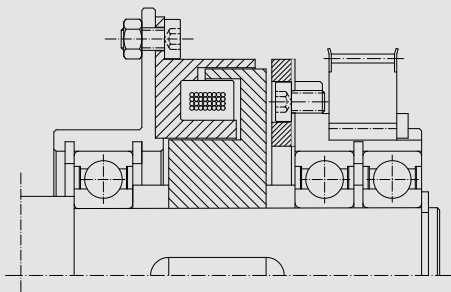

Assembly clutch:

The concentric connection to the magnet body is done by attaching it to an adapterplate, which is secured against turning by low bearing friction

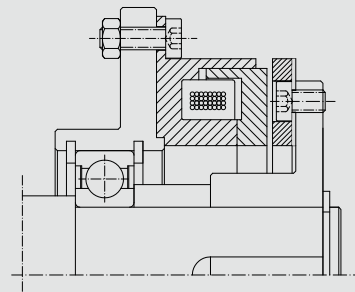

Assembly brake:

The assembly is done as with the clutch. Only the turning of the adapter plate is to be secured against the full torque of the brake.

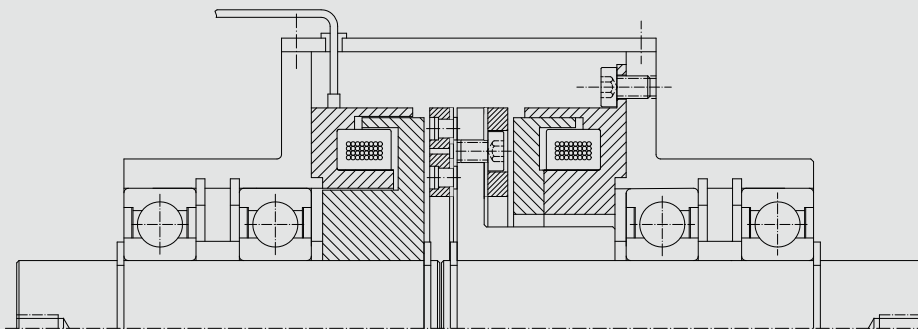

Clutch-brake combination in a housing:

Such combinations suit for drives where rotating mass must be accelerated and decelerated

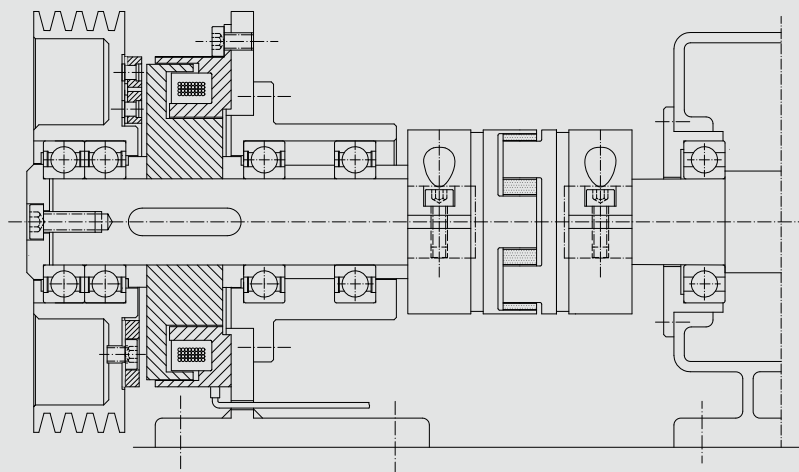

Connection input housing-gearbox:

Connection of input shaft with a coaxial mounted gearbox shaft occurs via flexible coupling. Misalignment of the both shafts can be compensated. A preferably precise run out of single disc brakes and clutches is important especially at high rpm.

Assembly of clutches

The magnet body has to be bolted fix with screws (d5) attached to a housing or adapter plate mounted on a shaft.

The centring can also be done via outer diameter D4 or bore hole D3. The rotor is fixed on the shaft and at measure "b" aligned and axial secured with the magnet body and thus precisely in position. This is also valid for the magnet body (D4/D3) which is centric to the shaft. The ring air gap between magnet body and rotor is resulting from this and has a constant gap value.

The armature disc and the membrane of the clutch is fixed with screws according to bore d3 to a connecting part. Is this connecting parts supported on the clutch shaft, then the armature disc is also in concentric position.

Under these circumstances the assembly of the clutch is easy and simple. A required connection to a second, coaxial shaft has to be done via a compensation coupling, to avoid a misalignment.

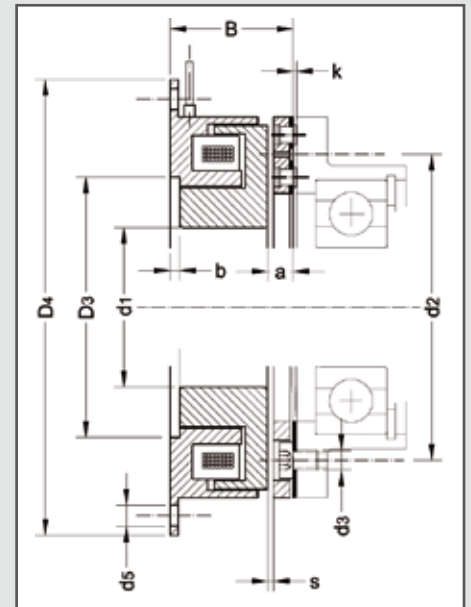

Assembly of brake

The assembly of the magnet body of the brakes is done in the same way as with the clutch.

Brakes do not have a ring air gap, which makes their assembly easier. The connection part with armature disc and membrane is connected with the braking shaft. Please avoid a radial misalignment. Permissible values are:

AB-AR	05	1	2	4	8	16
Eccentricity [mm]	0.20	0.25	0.30	0.30	0.35	0.40

Please consider that the connecting part of the magnet body has to transfer the full torque.

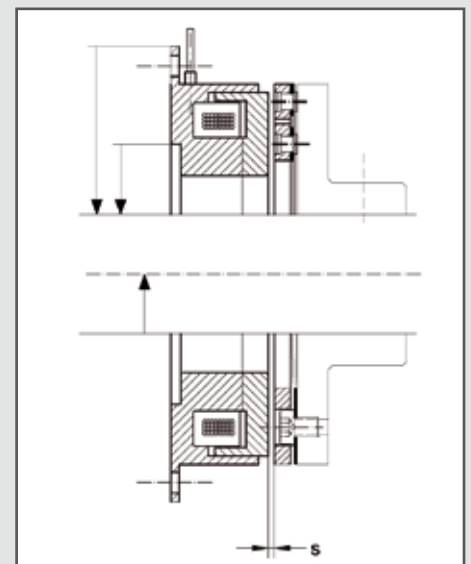

Inspection of shifting travel

The adjustment of shifting travel for clutches respective brakes and thus the air gap "s" between friction surface of rotor and armature disc occurs by adjustment of measure a+k. In the catalogue the measures a and k as well as s are given.

a+k equals:

AK-AR, AB-AR	05	1	2	4	8	16
a + k	3.5	4.5	5.5	6.5	7.5	9

Is a+k adjusted to a smaller value, then air gap respective shifting travel is smaller. The closing time is reduced, the braking time is longer due to the reduced deflection of the membrane.

Is a+k adjusted to a bigger value, then the shifting travel respective the air gap "s" is bigger.

The closing time is longer. The braking time is shorter due to the higher deflection of the membrane and its resulting higher forces.

If there is no special need it is recommended to adjust to the catalogue values.

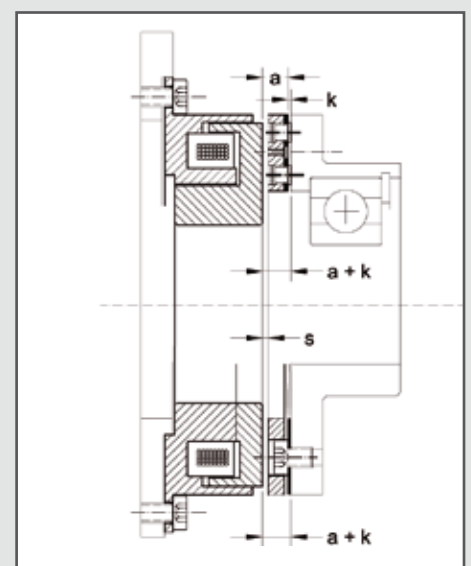

Order codes and technical description

Size	Order code	Technical description
AK-AR 0,5	9932 115 012	D20, keyway 6 x 1,7 24 V
	9932 115 013	D15, keyway 5 x 1,3 24 V
	9932 115 015	D12, keyway 4 x 1,1 24 V
	9932 115 016	D10, keyway 3 x 1,4 24 V
AB-AR 0,5	9932 115 010	24 V
Armature disc	9932 215 003	
AK-AR 1	9932 120 011	D30, keyway 8 x 1,7 24 V
	9932 120 012	D25, keyway 8 x 1,7 24 V
	9932 120 013	D20, keyway 6 x 1,7 24 V
	9932 120 014	D15, keyway 5 x 1,3 24 V
	9932 120 078	D25, keyway 8 x 1,7 24 V, 390 mm wire
	9932 120 018	D17, keyway 5 x 1,3 24 V
AB-AR1	9932 120 010	24 V
Armature disc	9932 220 086	
AK-AR2	9932 124 011	D40, keyway 12 x 2,1 24 V
	9932 124 012	D30, keyway 8 x 1,7 24 V
	9932 124 013	D25, keyway 8 x 1,7 24 V
	9932 124 014	D20, keyway 6 x 1,7 24 V
AB-AR2	9932 124 010	24 V
Armature disc	9932 224 004	
AK-AR4	9932 128 011	D50, keyway 14 x 2,6 24 V
	9932 128 013	D40, keyway 12 x 2,1 24 V
	9932 128 015	D30, keyway 8 x 1,7 24 V
	9932 128 016	D25, keyway 8 x 1,7 24 V
AB-AR4	9932 128 010	24 V
Armature disc	9932 228 004	
AK-AR8	9932 133 011	D60 2 keyway 18 x 3,1 24 V
	9932 133 012	D50 2 keyway 14 x 2,6 24 V
	9932 133 013	D40 2 keyway 12 x 2,1 24 V
	9932 133 014	D30 2 keyway 8 x 1,7 24 V
AB-AR 8	9932 133 010	24 V
Armature disc	9932 233 011	
AK-AR16	9932 138 011	D80 2 keyway 22 x 4,1 24 V
	9932 138 012	D60 2 keyway 18 x 3,1 24 V
	9932 138 013	D50 2 keyway 14 x 2,6 24 V
	9932 138 014	D40 2 keyway 12 x 2,1 24 V
	9932 138 020	D38 predrilled
AB-AR16	9932 138 010	24 V
Armature disc	9932 238 011	

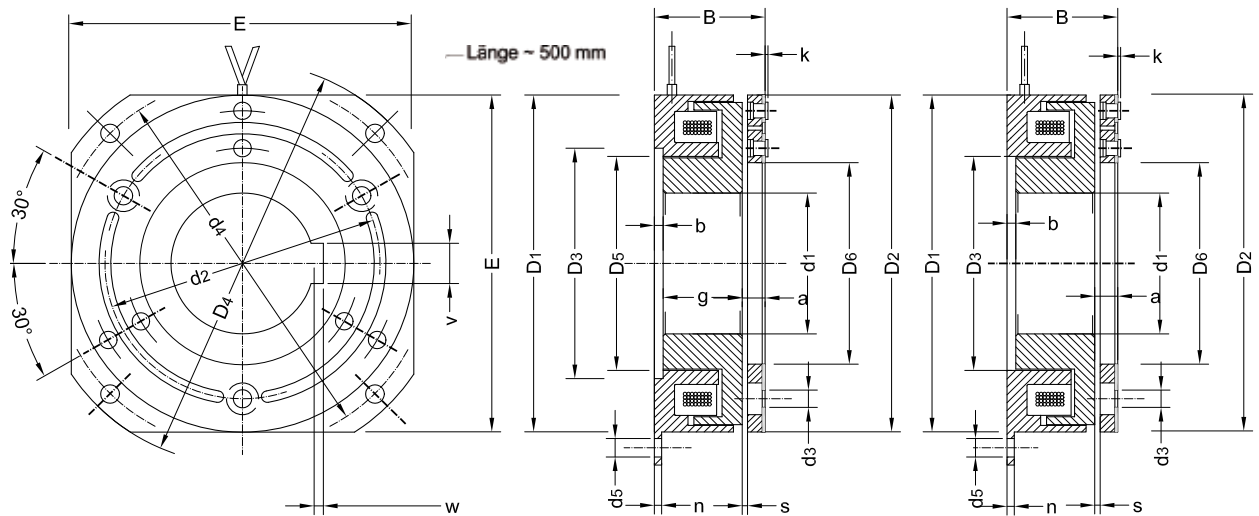

Dimensions: Single disc clutches

Dry run DC 24V (different current on request)

Specification and dimension		AK-AR 0,5	AK-AR 1	AK-AR 2	AK-AR 4	AK-AR 8	AK-AR 16
Transmittable torque	Nm	6	12	25	50	100	200
Shiftable torque	Nm	5	10	20	40	80	160
Coil power at 20°	W	10	12,5	20	25	31	42
Coil power at 120°	W	7.5	9	15	18	22	30
Rpm max	min ⁻¹	9000	8000	7000	6000	6000	6000
Shifting times	closing time t ₁	ms	30	50	70	100	160
	Braking time t ₂	ms	15	20	30	40	55
Weight app.	kg	0.35	0.66	1.24	2.15	4.00	7.10

Ø D ₁	mm	59	74	93	117	150	190
Ø D ₂	mm	58	73,5	92	116	147	186
Ø D ₃ H8	mm	42	52	62	80	90	110
Ø D ₄ H8	mm	72	92	115	140	180	220
Ø D ₅	mm	30,5	39,5	51,5	66,5	-	-
Ø D ₆	mm	34	43,5	54	70	90	112
Ø d ₁ max bore H7	mm	20	30	40	50	60	80
Ø d ₂ ±0.1	mm	46	58	74	94	118	150
Ø d ₃	mm	3.1	4.1	5.1	6.3	8.4	10.4
Ø d ₄ AK-AR 05 - 4 ± 0.1, AK-AR 8 - 16 ± 0.2	mm	66	83	104	128	165	205
Ø d ₅	mm	3.2	4.3	5.3	6.4	6.6	9
B	mm	25,2	29	33	36,5	43	47
E	mm	59	74	93	117	150	180
a ±0.1	mm	3,2	4,1	5	5,9	6,7	8
b AK-AR 05 - 4 ± 0.4, AK-AR 8-16 ±0.6	mm	2	2.5	2.5	3	6.5	7
g -0.1	mm	20	22	25	27	-	-
k	mm	0.3	0.4	0.5	0.6	0.8	1
n	mm	1,5	2	2	2,5	2,5	3
s	mm	0.3	0.3	0.3	0.3	0.4	0.4
V x W At maximum bore b	mm	6 x 1.7	8 x 1.7	12 x 2.1	14 x 2.6	18 x 3.1	22 x 4.1

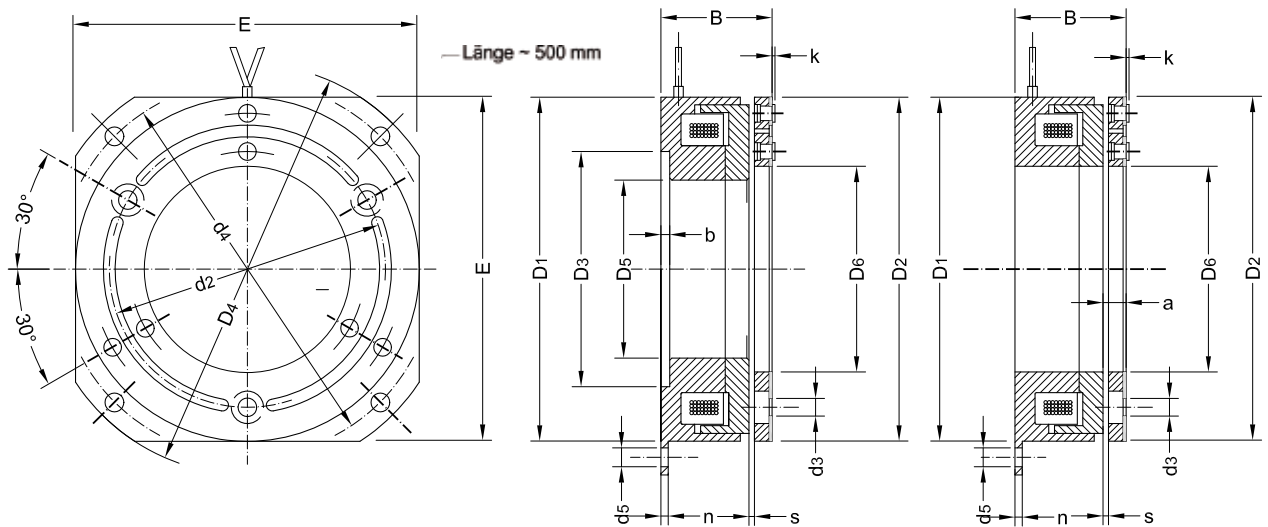

Dimensions: Single disc brakes

Dry run DC 24V (different current on request)

Specification and dimension		AB-AR 0,5	AB-AR 1	AB-AR 2	AB-AR 4	AB-AR 8	AB-AR 16	
Transmittable torque	Nm	6	13	25	50	100	200	
Shiftable torque	Nm	5	10	20	40	80	160	
Coil power at 20°	W	10	12.5	20	25	31	42	
Coil power at 120°	W	7.5	9	15	18	22	30	
Rpm max	min ⁻¹	9000	8000	7000	6000	6000	6000	
Shifting times	closing time t ₁	ms	30	50	70	100	130	160
	Braking time t ₂	ms	15	20	30	40	55	70
Weight app.	kg	0.35	0.66	1.24	2.15	4.00	7.10	

Ø D ₁	mm	59	74	93	117	150	190
Ø D ₂	mm	58	73.5	92	116	147	186
Ø D ₃ H8	mm	42	52	62	80	90	110
Ø D ₄ H8	mm	72	92	115	140	180	220
Ø D ₅	mm	30.5	39.5	51.5	66.5	-	-
Ø D ₆	mm	34	43.5	54	70	90	112
Ø d ₂ ±0.1	mm	46	58	74	94	118	150
Ø d ₃	mm	3.1	4.1	5.1	6.3	8.4	10.4
Ø d ₄ AB-AR 05 - 4 ± 0.1, AB-AR 8 - 16 ± 0.2	mm	66	83	104	128	165	205
Ø d ₅	mm	3.2	4.3	5.3	6.4	6.6	9
B	mm	25.2	28.6	32.5	35.9	42.2	46
E	mm	59	74	93	117	150	180
b AB-AR 05 - 4 ± 0.4	mm	2	2.5	2.5	3	-	-
k	mm	0.3	0.4	0.5	0.6	0.8	1
n	mm	1.5	2	2	2.5	2.5	3
s	mm	0.3	0.3	0.3	0.3	0.4	0.4

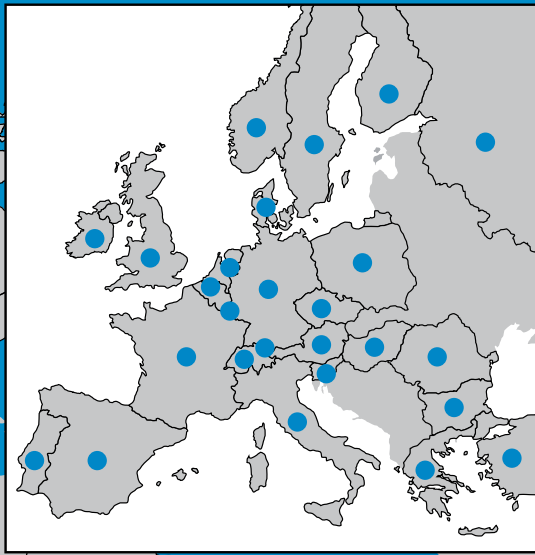

a&g automation and gears GmbH
Am Sandbühl 2
D-88693 Deggenhausertal
Fon.: +49 (0) 75 55 / 92 78 80
Fax: +49 (0) 75 55 / 92 78 80 1

E-mail: info@aundg.com
Internet: www.aundg.com